

VW-52

API 607 Fire Safe Approved

Full Bore 1/2"~16"(DN 15~ DN 600)
 Blow-out-proof stem design
 Lock Device
 Anti-Static design/ISO 5211 Mounting Flange
 Body:Stainless steel,Carbon steel,Special Alloy steel
 Ball: ASTM A-351 Gr.CF8M(EN 1.4408)
 Stem:SS 316
 Seat: PTFE +15% GF
 Temperature Range: -4 to 356°F(-20 to 180°C)
 Face to Face: ANSI B16.10 Class 150 / 300 / 600
 EN 558-1 F1 / F4 / F5
 Flange Dimensions: ANSI B16.5 Class 150 / 300 / 600
 EN 1092-1 PN10 / 16 / 25 / 40
 JIS 10K

Dimensions

Unit :mm

VALVE SIZE	A	B	C	D	E	F	H	H1	H2	L	W	S	T	Q	ØM-N
1/2"	15.0	35.1	60.5	88.9	130.8	1.6	65.7	22.7	12.5	108.0	11.0	42.0	11.2	1/4"-20	Ø15.74
3/4"	20.0	42.9	69.9	98.6	130.8	1.6	68.2	22.5	12.5	117.0	11.0	42.0	11.2	1/4"-20	Ø15.74
1"	25.0	50.8	79.2	108.0	165.0	1.6	80.6	29.3	15.5	127.0	14.0	50.0	11.2	1/4"-20	Ø15.74
1-1/4"	32.0	63.5	88.9	117.3	165.0	1.6	86.5	29.3	15.5	140.0	14.0	50.0	12.7	1/4"-20	Ø15.74
1-1/2"	38.0	73.2	98.6	127.0	202.0	1.6	108.9	38.4	21.5	165.0	17.0	70.0	14.2	5/16"-18	Ø15.74
2"	50.0	91.9	120.7	152.4	202.0	1.6	116.5	38.4	21.5	178.0	17.0	70.0	15.7	5/16"-18	Ø19.14
2-1/2"	63.0	104.6	139.7	177.8	202.0	1.6	139.0	38.4	21.5	190.0	17.0	70.0	17.5	5/16"-18	Ø19.14
3"	80.0	127	152.4	190.5	328.5	1.6	169.4	58.3	31.5	203.0	22.0	102.0	19.1	3/8"-16	Ø19.14
4"	98.0	157.2	190.5	228.6	328.5	1.6	193.3	60.3	33.1	229.0	22.0	102.0	23.9	3/8"-16	Ø19.18
5"	125.0	185.7	215.9	254.0	752.5	1.6	237.0	75.0	45.5	356.0	27.0	125.0	23.9	1/2"-13	Ø22.48
6"	150.0	215.9	241.3	279.4	752.5	1.6	256.0	75.0	45.5	394.0	27.0	125.0	25.4	1/2"-13	Ø22.48
8"	200.0	250.0	298.5	342.9	816.0	1.6	325.5	74.0	43.5	457.0	36.0	140.0	28.4	5/8"-11	Ø22.48
10"	250.0	323.9	362.0	406.4	1016.0	1.6	391.0	116.0	69.5	533.0	46.0	165.0	30.2	3/4"-10	Ø25.4-12
12"	300.0	381.0	431.8	482.6		1.6				610.0			31.8		Ø25.4-12
14"	350.0	412.8	476.3	533.4		1.6				686.0			35.1		Ø28.4-12
16"	400.0	469.9	539.8	596.9		1.6				768.0			36.6		Ø28.4-16
18"	450.0	533.4	577.9	635.0		1.6				864.0			39.6		Ø31.8-16
20"	500.0	584.2	635.0	698.5		1.6				914.0			42.9		Ø31.8-20
24"	600.0	692.2	749.3	812.8		1.6				1067.0			47.8		Ø35.0-20

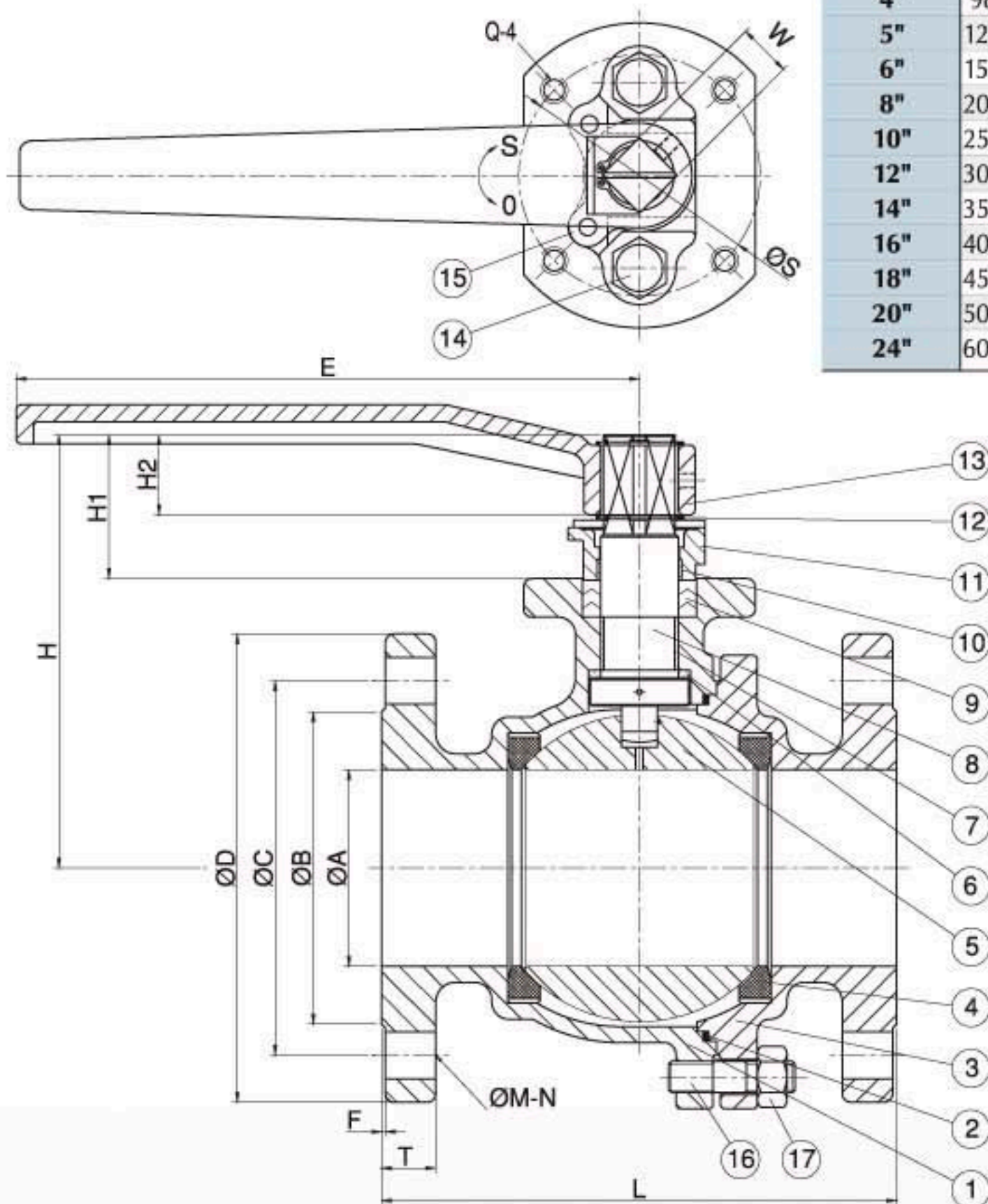

Material

No.	Part Name	Material
1	BODY	ASTM A351 Gr. CF8M
2	BODY SEAL	PTFE.
3	END CAP	ASTM A351 Gr. CF8M
4	SEAT	RTFE.(+15% G/F)
5	BALL	ASTM A351 Gr. CF8M
6	THRUST WASHER	PTFE.
7	STEM BUSHING	PTFE.
8	STEM	SS 316
9	STEM PACKING	PTFE.
10	GLAND BEARING	PTFE.
11	GLAND	SS 304
12	SNAP RING	SS 304
13	HANDLE	FCD 45
14	BOLT	SS 304
15	STOP PLATE	SS 304
16	STUD	ASTM A193 Gr. B8
17	NUT	ASTM A194 Gr. 8