



4-way Flanged Ball Valves, Full Bore, T-port, ANSI Class 150

K-508

Full Bore 1-1/2"~6"(DN 40~ DN 150)
 Split Body Trunn Mounted
 4 Way L / T Double L Port
 Anti-Static design / ISO 5211 Mounting Flange
 Body: Stainless steel, Carbon steel, Special Alloy steel
 Ball: EN 1.4408 (ASTM A-351 Gr. CF8M)
 Stem: SS 316
 Seat: PTFE +15%GF
 Temperature Range: -4 to 356°F(-20 to 180°C)
 Face to Face: Mfg. Std.
 Flange Dimensions: ANSI B16.5 Class 150 / 300
 EN 1092-1 PN16/40



Dimensions

Unit : mm

Valve Size	A	B	C	D	E	F	H	H1	H2	K	L	W	S	T	Q	ØM-N
1-1/4"	30.0	63.5	88.9	117.3	360.0	1.5	141.0	57.0	38.3	40.0	225.0	17.0	70.0	12.7	5/16 ^s -18	Ø15.7-4
1-1/2"	35.0	73.2	98.6	127.0	360.0	1.5	141.0	57.0	38.3	40.0	225.0	17.0	70.0	14.2	5/16 ^s -18	Ø15.7-4
2"	49.0	91.9	120.7	152.4	360.0	1.5	153.5	57.0	38.3	40.0	254.0	17.0	70.0	15.7	5/16 ^s -18	Ø19.1-4
2-1/2"	64.0	104.6	139.7	177.8	360.0	1.5	161.0	57.0	38.3	40.0	260.0	17.0	70.0	17.5	5/16 ^s -18	Ø19.1-4
3"	76.0	127.0	152.4	190.5	520.0	1.5	173.7	62.5	40.0	50.0	282.0	22.0	102.0	19.1	3/8 ^s -16	Ø19.1-4
4"	100.0	157.2	190.5	228.6	757.5	1.5	234.8	86.8	60.0	70.0	332.0	27.0	125.0	23.9	1/2 ^s -13	Ø19.1-8
6"	148.0	215.9	241.3	279.4	950.0	1.5	271.5	99.0	64.7	90.0	442.8	36.0	140.0	25.4	5/8 ^s -11	Ø22.4-8

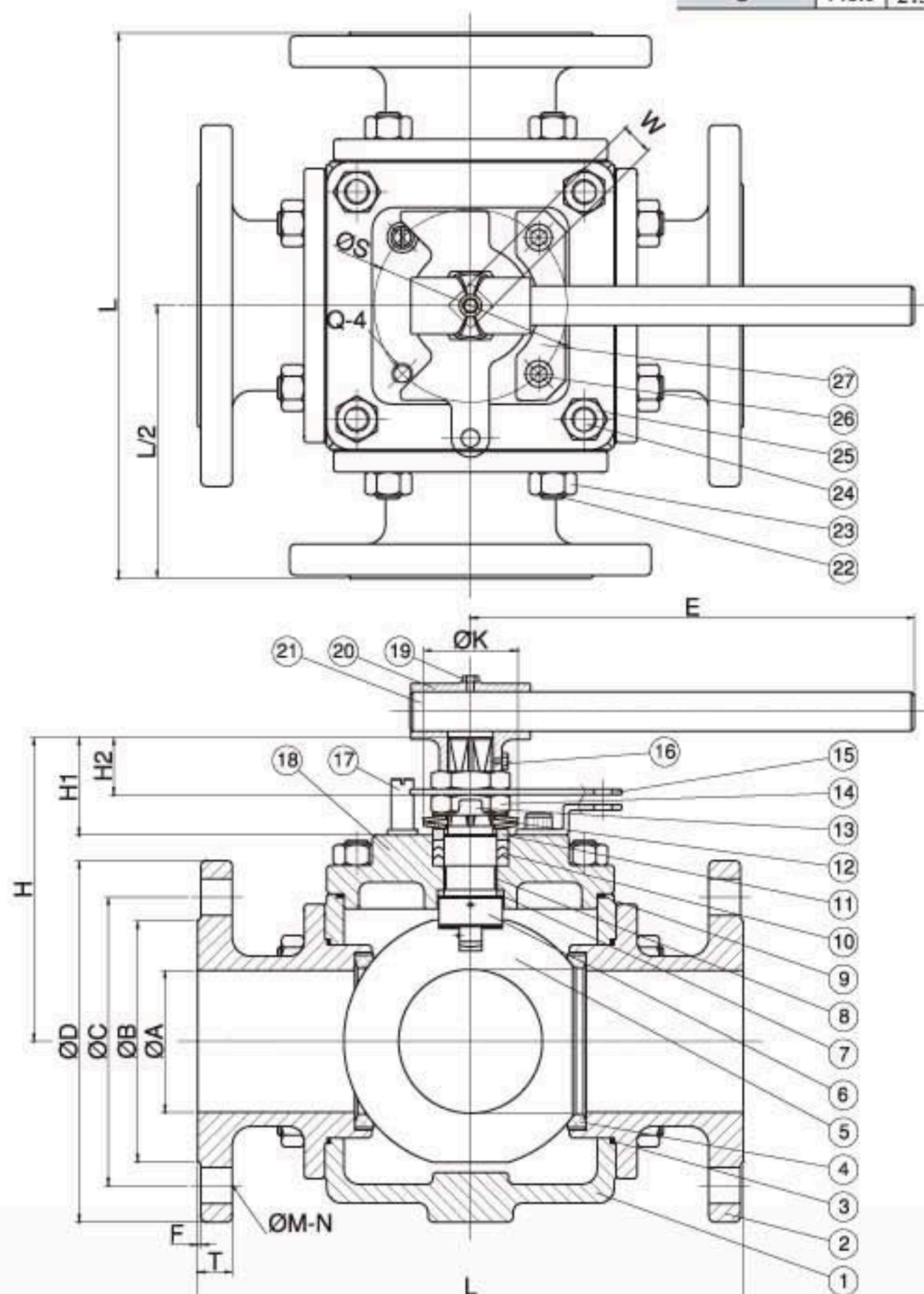

Material

No.	Part Name	Material
1	BODY	ASTM A351 Gr. CF8M
2	END CAP	ASTM A351 Gr. CF8M
3	BODY SEAL	PTFE.
4	SEAT	RTFE.(+15% G/F)
5	BALL	ASTM A351 Gr. CF8M
6	STEM	SS 316
7	THRUST WASHER	PTFE.
8	STEM BUSHING	PTFE.
9	TOP COVER SEAL	PTFE.
10	STEM PACKING	PTFE.
11	GLAND	SS 304
12	BELLEVILLE WASHER	SS 304
13	STOP WASHER	SS 304
14	STEM NUT	SS 304
15	STOP PLATE	SS 304
16	HANDLE ADAPTER BOLT	SS 304
17	STOP PIN	SS 304
18	TOP COVER	ASTM A351 Gr. CF8M
19	HANDLE BOLT	SS 304
20	HANDLE ADAPTER	SS 304
21	HANDLE	CARBON STEEL
22	STUD	ASTM A193 Gr. B8
23	NUT	ASTM A194 Gr. 8
24	TOP STUD	ASTM A193 Gr. B8
25	TOP NUT	ASTM A194 Gr. 8
26	BOLT	SS 304
27	LOCKING PAD	SS 304